

Fortification Basics

Wheat Flour

Rationale

Wheat is the most widely produced cereal in the world, most of which is destined for human consumption; thus, its contribution to energy intake is significant, particularly in the Americas and the Middle East (Table 1).

The processing of whole wheat to wheat flour is generally concentrated in a few large mills. The resulting flour is used to make bread, biscuits, pasta, and other products. Because of its widespread geographic distribution, acceptance, stability, and versatility, wheat flour is a suitable vehicle for delivering micronutrients to mankind.

Micronutrient Content of Wheat and Wheat Flour

In its natural state, wheat is a good source of vitamins B1 (thiamine), B2 (riboflavin), niacin, B6 (pyridoxine), E, as well as iron, and zinc.

Nevertheless, because most of these nutrients are concentrated in the outer layers of the wheat grain (Figure 1), a significant proportion is lost during the milling process. For lower extraction rates of flour (i.e. more refined flour), the loss of vitamins and minerals is greater (Figure 2).

Nutrients Generally Added to Wheat Flour

In developed countries, wheat flour is generally fortified with vitamins B1, B2, niacin, and iron. In some countries calcium and folate are also added. Vitamins A and D can also be added to flour.

The levels of vitamin B1, niacin, and iron added to wheat flour is often equivalent to the amount lost in milling, i.e. these micronutrients are restored and the flour is *enriched*. For other micronutrients such as vitamin B2, the amount added is over and above that lost in milling, i.e. the flour is *fortified*.

Fortification rather than enrichment is done when the overall diet is deficient in particular micronutrients and restoring the micronutrients lost in milling will not make good this deficit.

Technology

The technology for fortifying flour is simple. First, a premix

Table 1
Per Capita Wheat Consumption
in Selected Countries

Country	Consumption (g/person/day)	% of Daily Energy Intake
Pakistan	318	45
Turkey	484	44
Syria	490	44
Chile	372	42
Egypt	397	35
Greece	371	28
Argentina	344	28
Uruguay	269	26
Bolivia	159	20
South Africa	191	18
Peru	136	17

Figure 1
Schematic Diagram of the Wheat Grain

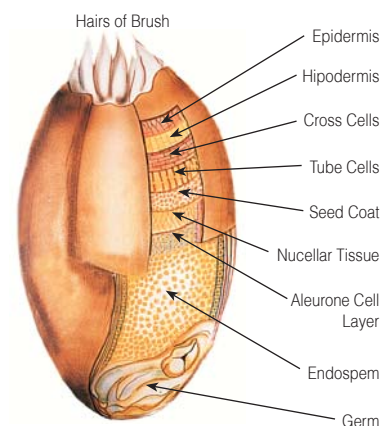
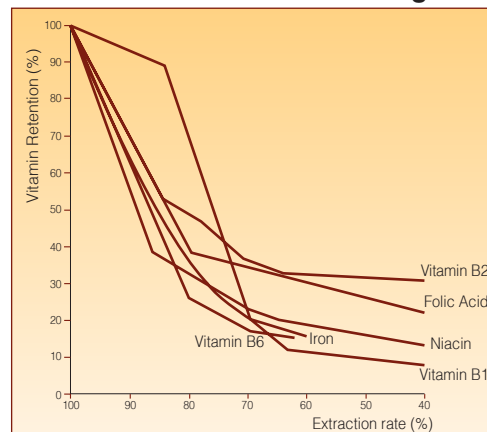

Figure 2
Changes in Micronutrient Content
of Wheat Grain with Milling



Adapted from FAO. 1970. Wheat in Human Nutrition and Thomas. B. 1968. Nutritional - physiological views in processing cereal products. Vegetables. 15: 360.

Table 2
Example of Premix Composition

Nutrient	Level (mg/Kg Flour)	Product Form	grams/Kg Premix
Vitamin B ₁	4.45	Thiamine Mononitrate	61.80
Vitamin B ₂	2.65	Riboflavin	36.90
Niacin	35.62	Nicotinamide	494.70
Iron	30.20	Reduced Iron	406.60

Dosage: 72 g/ton of flour

Figure 3
Volumetric Feeder for Adding Micronutrient Premix

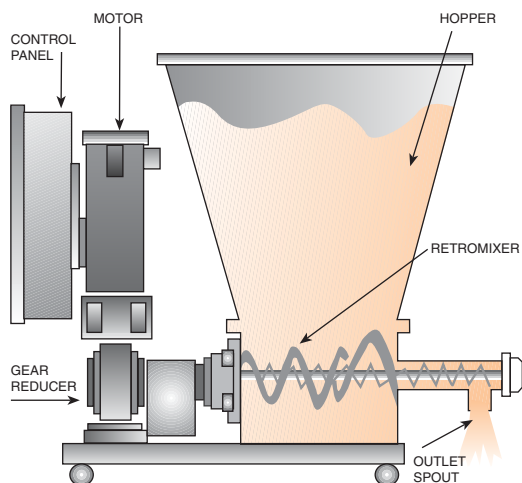
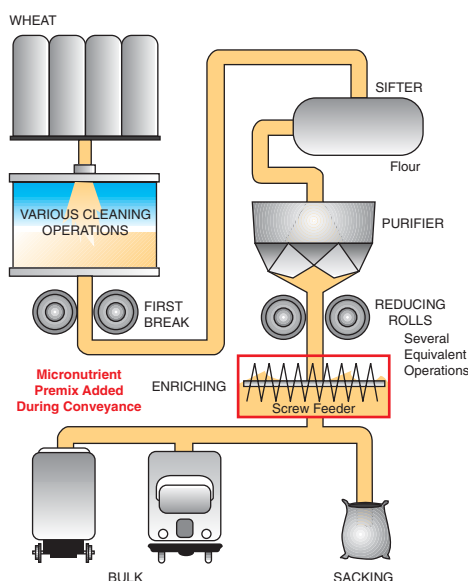

Figure 4
Simplified Flow Chart for Flour Milling



of the micronutrients to be added is needed (Table 2). The advantage of using a premix over that of adding micronutrients singly is that there is a greater likelihood of ensuring:

- The correct concentration of micronutrients
- An even distribution of micronutrients

Furthermore, the logistics of adding micronutrients to flour will be simpler and the quality assurance system is more likely to be effective.

The fortification process itself is accomplished by adding the micronutrients through a volumetric feeder (Figure 3) located towards the end of the milling process. The most commonly used feeder consists of a rotating feed screw that is driven by a variable speed motor. The screw rotates inside a chamber containing the premix and pushes the premix through an outlet spout. The amount of premix added to the flour can be modified by changing the motor speed. The concentration of premix added to the flour can be calculated by weighing the amount of premix deposited by the feeder in one minute divided by the volume of flow passing underneath in the same period of time. The premix can be either fed directly into the flour by gravity or by air convection using a *pneumatic* system. The homogeneity of micronutrients in fortified flour is largely dependent on the location of the feeder and it is very important that the mixing of the micronutrients with the flour is good. In a gravity driven system, experience has shown that the best site for adding micronutrients is before the mid point along the screw conveyor that collects flour from all the mill passages, just before bulk storage or sacking (Figure 4). If the feeder is placed towards the beginning of the screw conveyor, the amount of flour in the conveyor will be too little. If, on the other hand, the feeder is located toward the end of the screw conveyor, the required homogenisation will not be achieved.

In a pneumatic system feeders can be placed in a remote centralised location.

The cost of the feeder varies between US\$ 2000 and 5000, depending on whether a gravity or pneumatic system is installed and the quality of the device.

Micronutrient Stability

In foods, the stability of vitamins is more precarious than that of minerals because vitamins are sensitive to heat, oxidising and reducing agents, light, and other kinds of physical and chemical stress.

Vitamins are stable in flour as such, although high

humidity and temperatures together do adversely affect vitamin A. The use of encapsulated forms of vitamin A will help to overcome this problem. There is some evidence of minor losses of other vitamins during flour storage (Tables 3 and 4).

Most of the vitamin losses occur during baking, which is the most common process all wheat flour products go through. Although baking temperatures are high (over 200°C), the temperature inside the product is significantly lower, and over 70 percent of the vitamins remain unaltered (Table 5). Similarly, between 65 and 85 percent of vitamins remain intact after cooking pastas (Table 6).

Table 3
Nutrient Retention in Flour with 9% Humidity at Room Temperature

Nutrient	Label Claim	Level per Kg			
		Initial	2 mo	4 mo	6 mo
Vitamin A, IU	16,534	18,078	18,078	17,681	17,526
Vitamin B6, mg	4.41	5.18	4.85	5.07	4.85
Vitamin E, IU	33.07	35.05	35.05	35.05	35.05
Folic Acid, mg	0.66	0.82	0.66	0.77	0.66
Vitamin B1, mg	6.39	7.50	NR	NR	7.50

Table 4
Nutrient Retention in Flour with 9% Humidity at 45° C

Nutrient	Label Claim	Level per Kg			
		Initial	1 mo	2 mo	3 mo
Vitamin A, IU	16,534	18,078	16,534	14,175	12,919
Vitamin B6, mg	4.41	5.18	4.85	4.85	4.63
Vitamin E, IU	33.07	35.05	35.05	35.27	35.49
Folic Acid, mg	0.66	0.82	0.66	0.57	0.75
Vitamin B1, mg	6.39	7.50	NR	NR	NR

NR=Not registered
Cort, W.M., B. Borenstein, B., J.H. Harley, M. Osadca, and J. Scheiner. 1975. Nutrient Stability of Fortified Cereal Products. 35th IFT Meeting, Chicago, Ill.

Quality Control

The determination of micronutrients in flour can be done by simple classical methods (e.g. fluorometric for B1 and B2 and spectrophotometric for iron) or by faster methods that require more sophisticated equipment (e.g. HPLC for vitamin A, folic acid, and niacin and atomic absorption for iron).

It is important to establish quality control standards for both commercial premixes and fortified flour.

Legislation

Compulsory fortification of flour is increasing throughout the world. Currently 14 countries have legislation or regulations that mandate wheat flour be fortified with various micronutrients (Table 7). Other countries are

Table 5
Nutrient Losses During Typical Bread Baking

Nutrient	% Loss during baking
Vitamin A	10 - 20
Vitamin B1	15 - 25
Vitamin B2	5 - 10
Niacin	0 - 5
Folic Acid	20 - 30

F. Hoffmann - La Roche. Unpublished Data. Basel.

Table 6
Vitamin Losses in Long Durum Wheat Pasta After Drying and Cooking.

Nutrient	% Loss After Drying (75°C)	% Loss After Cooking
Vitamin A	13	17
Vitamin B1	0	32
Vitamin B6	5	35
Niacin	0	30

F. Hoffmann La Roche. 1990. Vitamins and Carotenoids in Pasta. Basel.

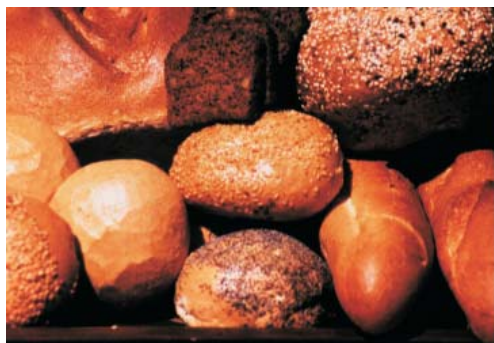
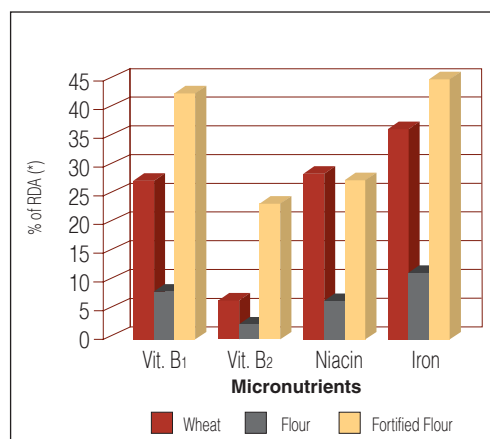
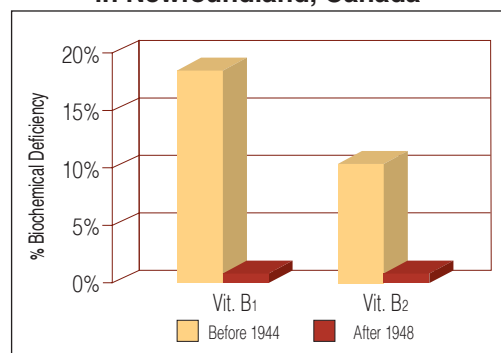

Figure 6
Nutrient Allowance per 100g of Different Wheat Products



Code of Federal Regulations. 1973. Enrichment Levels of Baked Goods, Flour Farina, etc. Title 21, 15.525. Nutrient data: ESHA Research, Food Processor II NCR. 1989, Recommended Dietary Allowances.

Figure 7
Biochemical Impact of Flour Enrichment in Newfoundland, Canada



Aykroyd, WR. et al 1949. Medical Survey of Nutrition in Newfoundland 1948. The Canadian Med. Assoc. Journal. 60:4.

Figure 8
Deaths from Niacin Deficiency in the U.S.A. Association with Wheat Flour Enrichment

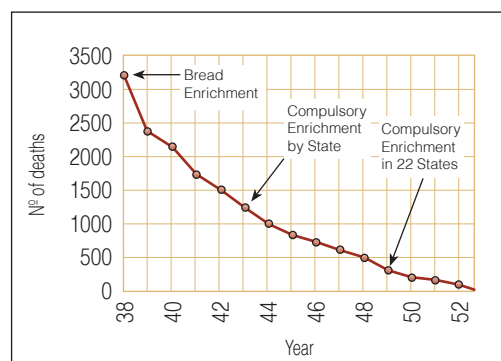

Miller, D.F. 1955. Enrichments Programs Helping Mother Nature Along Food Prod. Dev. 12: 4 30-38

considering this option. The low cost, and simplicity of the technology has made it one of the most sought after methods for combating micronutrient malnutrition. Figure 6, for example, shows the contribution that flour fortified with vitamins B1, B2 and niacin, as well as iron, makes toward meeting the Recommended Dietary Allowances (RDA) for adult men in the USA.

Table 7
Compulsory Flour Enrichment Worldwide

Country	Vitamin B1 (Mg/Kg)	Vitamin B2 (Mg/Kg)	Niacin (Mg/Kg)	Folic Acid (Mg/Kg)	Iron (Mg/Kg)
Canada	4.4 - 7.7	2.7 - 4.8	35 - 64	(0.4 - 0.5)	29 - 43
Chile	6.30	1.30	13.00		30.00
Costa Rica	4.4 - 5.5	2.6 - 3.3	35.2 - 44.0		28.7 - 36.4
Dominican Republic	4.45	2.65	35.62		29.29
Ecuador	4.45	7.48	83.58	0.59	58.65
El Salvador	4.41	2.65	35.30		28.70
Guatemala	4.0 - 6.0	2.5 - 3.5	35 - 40	0.35 - 0.45	55.65
Honduras	4.40	2.60	35.20		28.70
Nigeria	4.5 - 5.5	2.7 - 3.3	35.5 - 44.4		28.9 - 36.7
Panama	4.40	2.60	35.20		28.70
Saudi Arabia	≥ 6.38	≥ 3.96	≥ 52.91		≥ 36.30
UK	≥ 2.4		≥ 16.0		≥ 16.5
USA	6.40	4.00	52.90		44.10
Venezuela	1.50	2.00	20.00		20.00

Note: Figures in parenthesis indicate the enrichment is optional
Rauhnardt, O. and A. Bowley. 1996. Mandatory Food Enrichment. Nutriview 1.

Costs

The cost of fortifying wheat flour is much lower than generally recognised. For example, the total cost of adding mandatory nutrients to flour in the USA (i.e. 6.4 mg/Kg Vitamin B1, 4.0 mg/Kg Vitamin B2, 52.9 mg/Kg Niacin and 44.1 mg/Kg Iron), is less than one US Dollar per metric ton of flour. This is about 0.1 percent of the cost of flour in the shops.

On the other hand, if the cost in the USA is calculated on a per person per year basis, and average wheat consumption is 205 g/person/day, the total cost of fortification is US\$ 0.07 per person per year.

In addition to the recurrent costs for the micronutrients, there are the capital costs for the feeders, which are not great, and the recurrent costs for quality control.

Impact on Public Health

Figures 7 and 8 show the association between the introduction of fortification initiatives and the reduction in vitamin B1 and B2 deficiencies in Canada and niacin deficiency in USA, respectively.

Iron deficiency anaemia has also decreased in the USA, Great Britain, Sweden, and Chile and much of this decline is attributed to food fortification, including bread, with iron.